





User manual

LITAS headlight flash controller



Explanation of symbols

-  This indication informs you of special features of the system.
-  Background knowledge for the technical interrelationships of the headlight flash controller.
-  A recommendation for optimum procedure.
-  Warning instructions please read carefully and comply in all respects.
-  Risk of fatal injuries if disregarded.
-

Headlight flash controller LITAS 1

- **Door opening by headlight flashes**
- **Intelligent processing by microprocessor controller**
- **Headlight flashes adjustable from 2...5**
- **Light sensitivity adjustable**
- **Display by LED seven-segment module (digital display)**
- **Ignores other light sources**
- **Dual power supply**
- **Relay output, changeover contact**
- **External push-buttons can be connected**
- **Up to 6 reception sensors can be connected**
- **Easy to install**
- **Complete installation kit**

Functional description

The LITAS system allows switching operations to be triggered by a “headlight flash”. Therefore it’s perfectly suited to open doors for vehicles to pass through, for instance in car workshops, bus depots and train depots etc.

Door opening by headlight flashes:

The LITAS processing unit converts light pulses into electrical signals. If the unit has received the set number of flashes, the door opens.

Intelligent microprocessor controller:

The controller (processing unit) processes the headlight flashes. It discriminates on the basis of the number of headlight flashes, and when this matches the programmed setting an opening signal will be emitted. A pulse display is available for checking the unit.

Setting the number of pulses:

DIP switches allow the number of headlight flashes for opening the door to be set from 2...5. Furthermore the sensitivity can be set (short range 2.5m, long range 6m).

Light sensitivity adjustable:

A DIP switch allows selection of the short range or long range for light reception.

Display using the seven-segment display:

The selected number of pulses is displayed. The display is counted

down with each light pulse, and when zero is reached the output relay triggers. If no pulse has been received for 1.5s, the counter resets to the initial setting.

Ignores other light sources:

The intelligent LITAS processing unit is capable of distinguishing light pulses from other sources.

Dual power supply:

The LITAS 1 processing unit can be powered from a 10...40VDC or 230VAC power supply.

Relay output:

A potential-free changeover contact is provided as an output function.

External push-buttons:

Connection of external push-buttons allows an opening signal for the door to be triggered even when no vehicle is present.

Up to 6 sensors can be processed:

Several sensors, max. 6, can be connected in parallel.

Easy installation of sensors:

The neatly shaped flush-mounted sensors are encapsulated in a "snap-in" casing, which is simply pushed into the drilled hole.

Complete installation kit:

All necessary components are supplied.

Technical data

LITAS processor

Power supply	10...40VDC, or 230VAC, optionally 24VAC or 115VAC
Power consumption	(10-40VDC) 0.3W (230VAC) 1.5W
Output	Relay, changeover contact
Switching duration	>400ms
Switch rating	max. 1A/48VDC max. 5A/230VAC (ohmic load)
Displays	Seven-segment display (digital, 1 digit) Green LED=Power on Yellow LED=Relay triggered
External switch input	Push-button connection for manual operation
Headlight flash frequency	0.5...2Hz
Settings	Number of pulses and sensitivity adjustable using DIP switches
Connection terminals	pull off, screw fastening
Degree of Protection	IP 66 according to EN60529
Casing material	Lower part: Polycarbonate, grey Upper part: Polycarbonate, transparent
Operating temperature	-25°...60°C
Storage temperature	-35°...80°C
Weight	approx. 343g
Size	130x95x57mm ³ (LxWxH)



If no light pulse has been received for 1.5s, the system resets to the initial setting.

Technical data

Receiving sensor LITEM 1

Aperture	150° solid angle, photodiode
Index of Protection	IP 67, to EN60529
Casing material	PMMA
Connection cable	3×0.14mm ² , ø3.3mm, PUR
Cable length	6.5m (standard)
Number	max. 6 sensors
Operating temperature	-25°...60°C
Storage temperature	-35°...80°C
Weight	approx. 97g
Size	23mm long, ø16mm

Connections

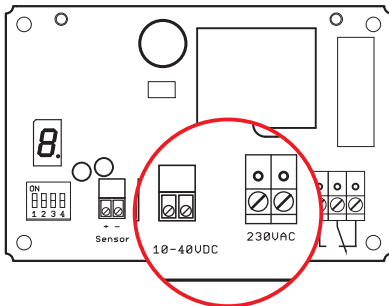

Power supply

The LITAS processing unit is suitable for 2 different power supplies.



Caution: Only connect one power supply!

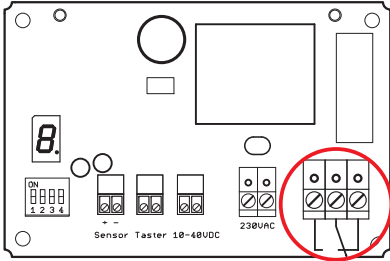

Relay output

A potential-free changeover contact is provided for connection as a signal emitter. After reaching the set number of pulses the relay triggers for approx. 1s and then drops out again. The yellow LED lights up when the relay is triggered.

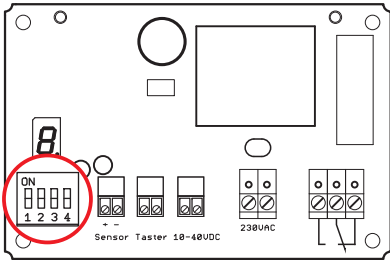

Settings by DIP switch

The DIP switches (1 and 2) allow the number of light pulses for opening the door to be set.

Furthermore switch 3 can be used to set the range. At the long range setting, the light can be received from 2...6m. At the short range setting the range is 0.5...2.5m.

Set the DIP switches as follows: 



2

headlight flashes



3

headlight flashes



4

headlight flashes



5

headlight flashes



long range



short range

Switch 4 is not used.

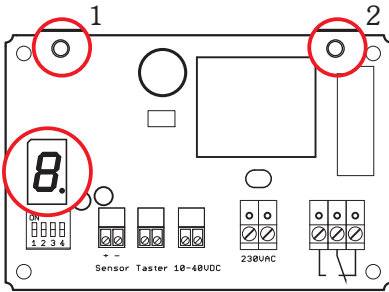

Visual indicators

The green LED 1 lights up when a power supply is present.

The yellow LED 2 lights up when the relay is triggered.



After the unit is switched on, the digital display shows the pre-set number of headlight flashes.

Each headlight flash that is received is acknowledged by the dot on the display lighting up, and the display counts down.

When the count-down reaches zero, the opening contact is triggered, and the yellow LED lights up. The unit then remains in wait mode for 1s, displaying zero. The unit then reverts to the start status.

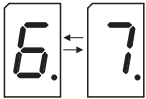

⇒ If an internal fault occurs in the controller, the digits six and seven are displayed alternately.

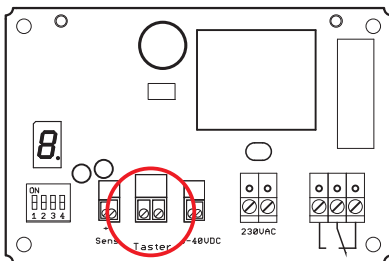

External push-buttons

External push-buttons can also be connected for opening the door.

This option allows the door to be opened even when no vehicle is present.

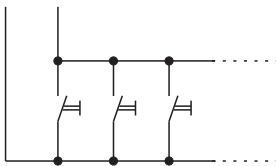

The push-buttons must be potential-free and wired in parallel. External voltages would invalidate the processing.

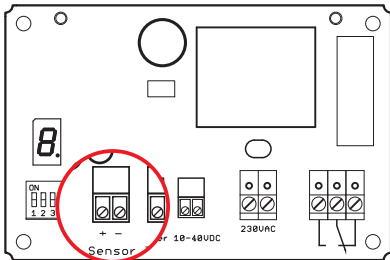

Sensor connection

Up to 6 receiving sensors can be connected in parallel to the LITAS processing unit.

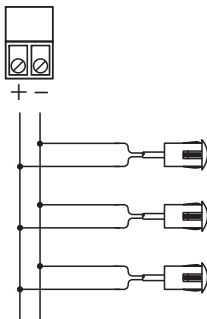

Please ensure that the polarity is correct.

Receiving sensor Model LITEM 1

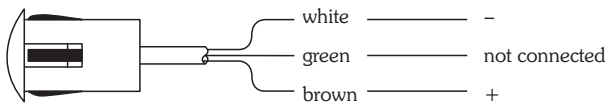

The green core is not connected.

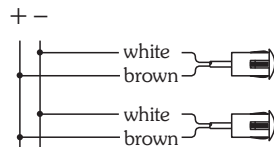

Installing the sensors

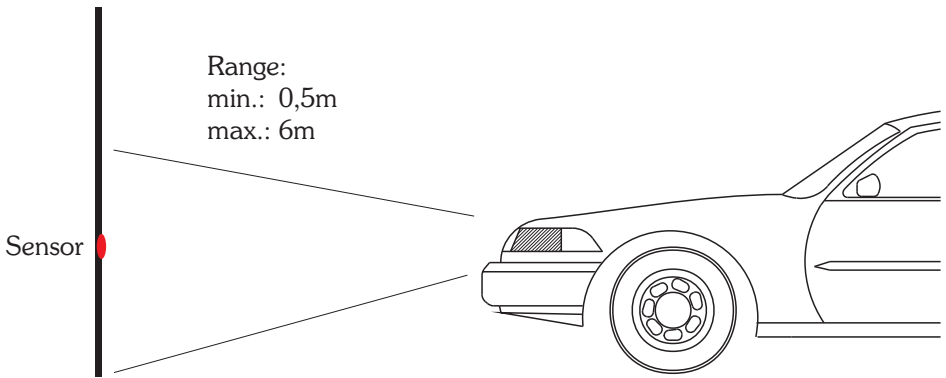

The optimum position for the sensors is in the centre of the headlamp beam.

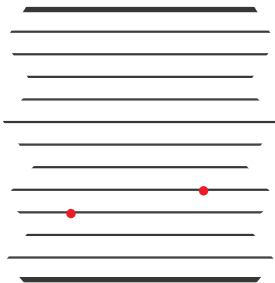

If various types of vehicles use the LITAS system, the sensors should be installed at different heights, so as to cater for the largest range of headlamp alignments.

Size

Sensors

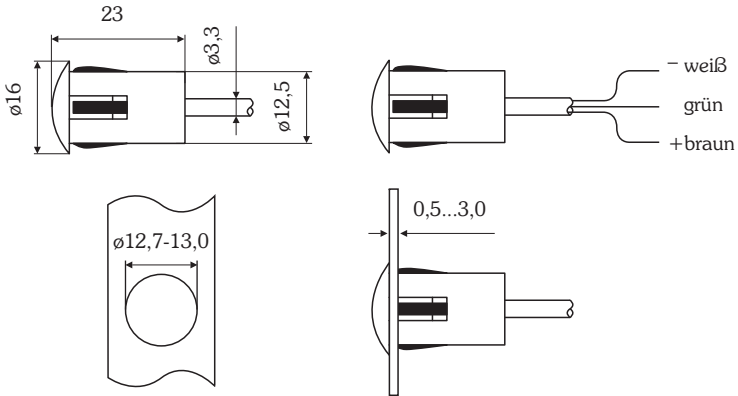

Processing unit

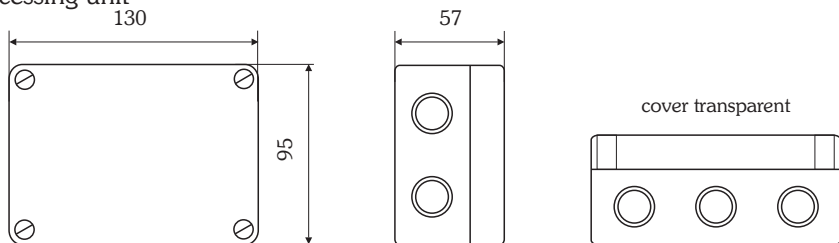

Cable junction box

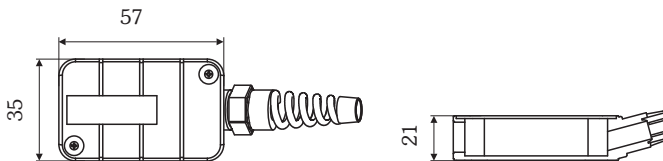

Spiral cable

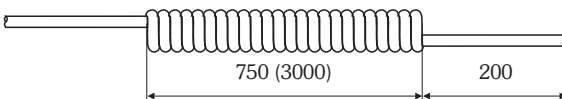

Drilling template

Screw diameter max. 5mm

M1:1

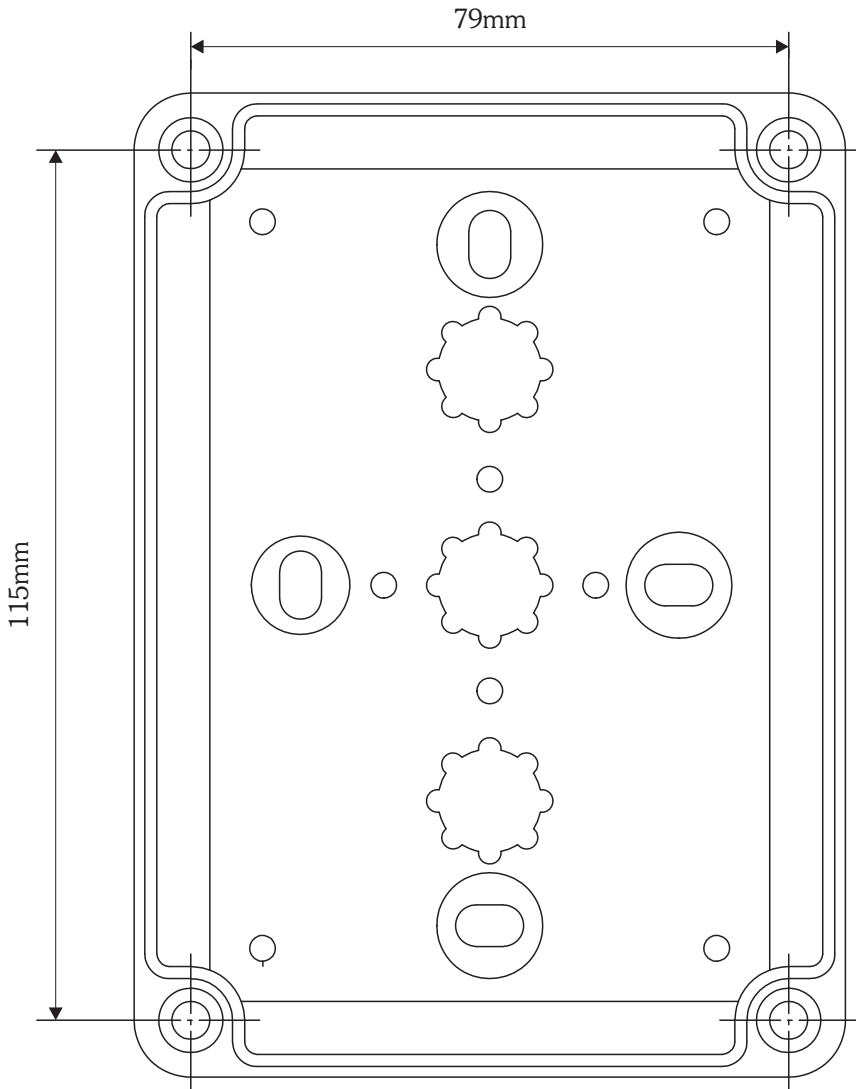

Ordering details

Headlight flash controller LITAS 1 1.114 040

Included in the scope of supply: 1 processing unit,
1 LAD1 cable junction box,
2 LITEM 1 sensors (Snap-In) 6,5m cable length,
1 spiral cable 3x0,5, spiral length 750mm,
3m usable length, 200mm each end,
40mm without sheating + wire end sleeves,
1 cable gland M16
1 cable gland M16 with anti-kink protection
2 M16 nuts

LITEM1 single sensor: 1.114 045

Declaration of conformity CE

This device complies with the standards listed below:

EMC directive 89/336/EEC
EN 61000-6-2 and EN 61000-6-4



Witt Sensoric GmbH
Gradestraße 48
D - 12347 Berlin

Tel.: +49 (0)30 75 44 94- 0
Fax: +49 (0)30 75 44 94-11

www.witt-sensoric.com